



Official Newsletter of the
Border Street Rod & V8 Club

September
2009

www.borderstreetrod.co.za
P.O.Box 8060; Nagoon; 5210

Wizards Chatter

Chairman's Chirp

Hi folks,

On Sunday the 23rd August the guys attended Peters Picnic which was organised by Allistar. The event was well supported by the public and it was nice to see some of our club cars on display. Thanks to the members who attended and thanks to all who displayed their cars. The farmers are preserving a different heritage in farm implements. Interesting statistics regarding the website. The website has grown in popularity and currently has over 17000 hits per month. Bruce is planning new pages and is inviting the members to provide him with photo's and articles of interest or maybe a new project. On the 5th September we are having our darts and potjie event at Comrades Club. Our chefs are lined up and excited to outdo each other for the best tasting potjie. Please let us know if you will be attending for catering purposes. Guys this is serious so practice as this is a competitive event and we normally have lots of fun and laughter. The guys who would like to attend our weekend away please phone Glen Muir (0437343032) and make your bookings in advance. Joyce has pre booked the venue for the club. The accommodation ranges from tent and caravan spots to chalets for two to six people. The program for the weekend is very relaxing with the Friday evening braai and of course the highlight being the Saturday evening potjie/braai and karaoke evening. This always turns out a surprise with all our clubs hidden talents. So don't miss out.



Just a thought for the month " When we are no longer able to change a situation
We are challenged to change ourselves"



Editorial

Can you believe it, this is the 6th issue of Wizards since I took on the post of scribe at the beginning of the year. I must say, that although challenging with all the usual hang ups and disappointments it has so far been a rewarding task. My greatest wish is that you the members enjoy reading it as much as I do compiling it. Please, if any of you have any ideas to improve the publication let me know and if you can let me have articles for publication it will be most appreciated. To those of you who have been giving me articles, thank you very much, it certainly helps me no end. If you are one of those observant types you may have noticed a slight change to the front page this month. The reason for this is that I normally have to edit out material in order to fit everything into the news letter. I have therefore endeavored to make more use of the existing space. Firstly I felt that an index was unnecessary in a publication of only 4 pages so out it went. Club clothing remains in an abbreviated form and sponsors names will appear on the back page with a brief description of their product and a contact number. To the ladies, please let me have a copy of your favorite tried and tested recipe's. The good news is that we are back on the Web and this means that you can access this and other news letters at any time. (www.borderstreetrod.co.za). If you haven't any idea how to access this site (as was the case with myself until recently), then just ask one of your children or grandchildren as I did. Well done! Remember above all, this is your news letter, please give it your support by letting me have any article that you think would be of interest to members. Thank you. In conclusion a big vote of thanks to Bruce for maintaining and updating the website. Please people, let Bruce know of anything relating to motoring news and photographs of interest to include in our website.

Golf Shirts:
R80-00
Pocket Badges:
R15-00
License Disk Holders:
R2-00
Name Badges
And shirts can be

Percy & Nicky

The latest new members to join our ranks are Percy & Nicky. Welcome both of you to the finest motoring club on the Border. One of the reasons I really enjoy putting together these reports is that it helps all of us to get to know one another, our likes, dislikes and so on. Fact is I thought Nicky was a teenager only to learn that she has a teenage 14 year old daughter Dianca! Percy has a love for Opels which inspired him to launch an Opel car club in EL. He possesses a 2001 Corsa and a 1999 Astra. This newly formed club will see the Comrades as their home and we all wish Percy the best of luck with this venture. Any of you guys out there with Opels of any description wishing to join the club can contact Percy on 0825944544. Percy is a true car enthusiast, it would appear that it not only is his hobby but also his business as he has his own service centre called "Noah Service Centre" situated at 2 Ajax Cres. in Cambridge. Please guys we all try to support each other so if you require service for your car, go and see Percy. He specializes in Opel and Isuzu petrol and diesel. Nicky shares her partners love for cars and they originally met whilst both working for Meyers Motors. Nicky remains in the motor trade and is at present employed by Ronnies Motors as a Supervisor of their vehicle stock books. When asked what attracted them to each other, Percy just loved her sense of humor and that being born out with Nicky's comment that she fell for his sexy butt!! (hey ladies there's another rear end to fascinate you at noggins other than mine for a change!!!). When it comes to hobbies and pastimes, Percy enjoys fishing and coin collecting. When it comes to cooking and entertaining friends he is in his element as he loves it. They both enjoy watching rugby and support the Blue Bulls and again they have a joint interest in watching motor sport. They would like to see Massa as this years formula one winner all be it that it has now become unlikely after his freak accident (interesting to note here that Shoemaker's return in place of Massa puts a huge question mark on how the



Recipe of the month

Spicy Streetrod Potatoes **Lisa Thomson**

This delicious Indian dish is a great accompaniment to meat, and is especially good served at a barbecue. This is also an excellent way to jazz up leftover potatoes.

4 tbsp oil
2 tsp ground cinnamon
1 tbsp ground coriander
1 tsp cayenne pepper
1 tbsp whole caraway seeds
2 tsp sesame seeds
2 tbsp butter
2.5 cm (1 in) piece of fresh ginger, peeled and grated
2 cloves garlic, crushed
750 g (1 3/4 lb) potatoes, unpeeled and cooked, then cut into 2.5 cm (1 in) square cubes
pinch of salt
4 tbsp chopped fresh coriander

1 Pre-heat oil in a heavy-based saucepan. When hot, add spices and seeds. When seeds pop, reduce heat. (Cooking the spices brings out their aromatic flavour.)

2 Add the butter, ginger and garlic. Cook for 1 minute, stirring constantly to prevent burning (if garlic burns, it becomes very bitter).

3 Add potatoes to the pan, and heat through for 8-10 minutes on medium heat, stirring occasionally to prevent them from catching on the bottom of the saucepan.

4 Season with salt and sprinkle with coriander. Spoon into a serving dish and serve the hot potatoes immediately.
SERVES 4-6.



rest of the season will work out. I have it on authority that Micheal's points, if he makes any, will not be credited to Massa but to himself and the other question remains what happens to Micheal if Massa is declared fit to race before the end of the season?). Percy was born in Kimberly where he graduated from Kimberly Technical High School, while Nicky was born in Berlin where she attended junior school then on to KHS in King and ultimately East London Technical Colledge. If we look at Nicky's hobbies we find her interests are also coin collecting and cooking (hey too many cooks spoil the broth remember) and then collecting Chinese ginger jars and ornaments, art and antiques. Her latest hobby is fishing so it would appear that this couple share each others interests. When eating out its Chinese food for Nicky and oxtail/ribs for Percy. Percy's dream car is a Mustang and Nicky would settle for a Transam as long as it is black with a golden eagle on the bonnet. The only improvement they would like to see in our club is the repair to the driveway entrance. (good point, I will bring this up at the next committee meeting). Finally, if they won the lotto Percy would buy his own Business premises and Nicky would travel....guess where....yes of course, to CHINA, just think of all those lovely Chinese ornaments and things that she would bring back. As for club outings they enjoy car shows most. So Percy and Nicky, We hope all of your dreams come true (somebody has to win the lotto!) and we look forward to having you as members of our club for many years to come. God bless you both.

Trevor.
STOP PRESS.....Percy has the nick name of "Captain" So now we have 2 Captains in our club, or could this young gentleman be our future chairman????Nicky's nick name is "Nix" so work that one out!!



Well this is my first time to report on my doings and don'ts. It took a long time to build the Cobra, ± 3 years and still doing things on the car which I am not happy with. I am still continuing to alter and modify the car. Thanks to my wife's interest also. The colour was her choice. Why a Cobra? It is the shape and engine sound. I bought the kit from Peter Pape for R 40,000.00 with an incomplete running chassis, a 283 Chevy engine and 350 turbo auto g/box. How much the whole project cost! ag nee man next question. I am quite proud of the fact that all work was done out of my home garage, except for the 2 front seats which was upholstered in town. I am busy with a 350 Chevy engine at the moment to replace the 283 engine in the Cobra and maybe go for a 5 speed manual g/box. I like to drive the Cobra as often as possible, but the East London weather does not allow it. Shirley, my wife would like to go shopping with it but she said the boot is too small.

Prizes won at the shows and club. Thanks to the judges and other club members.
 2007 Best engine bay. 2007 2nd Exotic car of the year. 2008 1st Exotic car of the year.
 2008 Car of the year. 2009 Best exterior.

The hi-light of it all was when I put the license disk and number plates on. No more ducking and diving from the traffic police. My next project is a Ford Anglia with a 1600 Kent motor and a 5 speed g/box. I also plan to upgrade the suspension and brakes. I have not decided on the colours as yet. Just a word of concern to the guys with smart looking cars, don't fool yourselves the ladies are not looking at you but at your car!

TECHNICAL TIME

Transmitting The Power

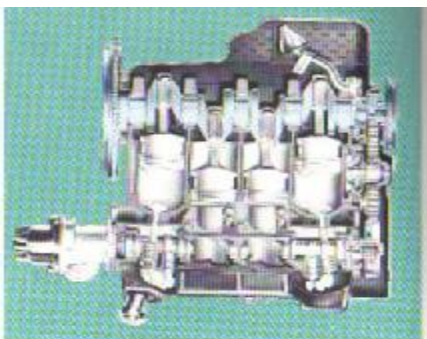

THE CRANKSHAFT, revolving in most cars at up to 6000 times a minute, transmits power to the gearbox, and so to the wheels. It is cast or forged in a single piece and in places is machined to an accuracy of less than 0,025 of a millimetre.

The main parts of the shaft are the journals. The main journals rotate within bearings which are supported in the crankcase. The crank-pins rotate within bearings in the big end of the connecting rod, thus allowing power to pass from the piston to the connecting rod and then the shaft. The journals are joined by balancing cranks, or webs, for smoother running.

The flywheel, a heavy and carefully balanced disc fitted at the gearbox end of the crankshaft, helps smooth running by maintaining a steady rate of turning.

With the downward thrusts of the pistons giving repeated sudden thrusts to the

crankshaft as the flywheel maintains its momentum, the shaft is subject to slight twisting and untwisting, known as torsional vibration. A damper - a metal disc incorporating a ring of rubber - is fitted to the front end of the crankshaft to help control torsional vibration.

The firing order of the cylinders is also important in making the crankshaft rotate smoothly. Counting the cylinder nearest the fan as No. 1, the firing order in a 4-cylinder engine is usually 1, 3, 4, 2 or 1, 2, 4, 3, so as to give reasonably even turning of the crankshaft.

On their firing strokes, the pistons push the crankshaft down; and on their other three strokes they are forced up or pulled down by the continuing rotation of the crankshaft. The crankpins are set at different angles to the shaft so as to give a uniform spacing of the firing impulses.

Sponsors

Trandy: Ink, Toner, Cartridges etc.
phone 0865136975

Telequack: Repairs to telephones,
fax machines and supplier of Orion
& Venus phones. 0834899137

Autolec: Auto electric service and
repairs phone 0437431218

Streak-A-Head: Latest styles in
hairdressing phone 0437411244

O&K Plant & Vehicle mainte-
nance phone 0437311535

Dennis McCullum repairs.
Electric gates, intercoms etc.
phone 0437439728

Monthly Raffle

The Club Raffle for last
month was won by:

Chevy Lee

Well Done!

**Amatola Classic car
run 28th November**

The Committee

Chairman - Johan Hattingh (hattingj@telkom.co.za)
(043 - 741 2577; Cell: 082 412 3365)

Vice-Chairman - Kevin Clayton
(043-7412403; Cell: 083 500 6185)

Secretary - Kobus Maritz (maritzjs@mweb.co.za)
(043 - 7263431; Cell: 083 419 3639)

Treasurer - Alma Henderson
(donhenderson@telkomsa.net)
(043 - 7353327; Cell: 083 306 7666)

Events Co-ordinator - Joyce Hattingh
(telequack@telkomsa.net)
(043 - 741 2577; Cell: 084 798 6248)

Assistant Events Co-ordinator - Magda Maritz
(maritzjs@mweb.co.za) (043 - 7263431)

P.R.O. - Carol Nicholson
(carol.nicholson@za.pwc.com) (043 - 7073203)

Scribe Trevor Browne
(trevorbrowne@absamail.co.za) (043 726 4798, Cell
082 499 5334)

Clubhouse Co-Ordinator - Shaun Eberhardt
(seberhardt@um.co.za)
(043 - 726 5772 ; Cell: 083 500 1355)

Chief Judge / Score Keeper - Barry Gradwell
(barry.gradwell@crestchem.co.za)
(Cell: 082 469 3136)

Something to Think About!



I know I'm not going to understand women.
I'll never understand how you can take boiling
hot wax,
pour it onto your upper thigh, rip the hair out
by the roots, and still be afraid of a spider..

Forthcoming Events

5th September... Potjie evening at Comrades Club.

3rd to 5th October weekend at Glen Muir (see chirp on front page)

The best way to remember your wife's anniversary is to forget once



JUST JOKING

A urologist decides he's had enough of being in the medical profession and decides to take a crash course in motor mechanics. At the end of the course he had to do a practical exam, the procedure involved removing the starter motor, dismantling it, re-assembling it, replacing it and then starting the engine. After he had successfully undertaken this assignment the instructor awarded him 150%. He was astounded, as surely 100% was the maximum mark, so he approached the examiner and asked for a breakdown of the marks. The examiner explained that 50% was for taking the starter out and dismantling it successfully, 50% was awarded for reassembly, refitting and starting the engine. The other 50% was awarded because never before had the entire procedure been carried out through the exhaust pipe!!

Walking along the beach recently I saw this beautiful piece of driftwood and then, by chance, noticed a young lady sitting on it. Seeing a storm was imminent and being a gentleman I offered her my left handed umbrella!!!!!!

Happy Birthday

